

S930F Soft Serve Freezer Table Top

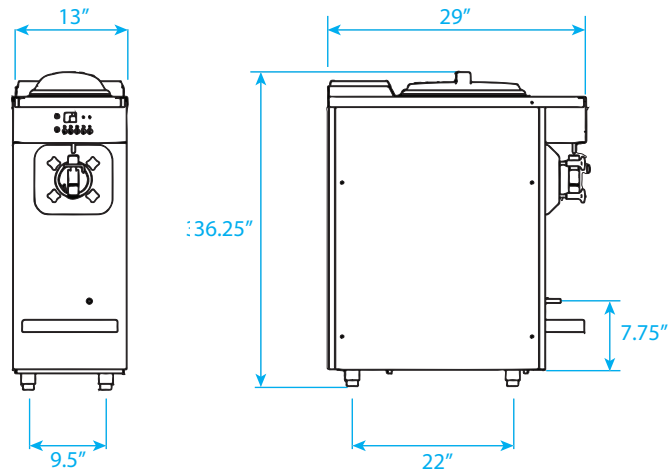

www.pasmouusa.com
1-844-527-2766



Technical Specs:

GENERAL INFO

MODEL NUMBER	S930F
TYPE	table top
PRODUCTION CAPACITY	50 L / H
NUMBER OF FLAVORS	1
NUMBER OF HOPPERS	1
HOPPER CAPACITY	9 L (2.37 gal)
SPECIFICATIONS	13" x 29" x 36.25"
CARTON SIZE	17" x 33.5" x 41.25"
NET WEIGHT	220 Lbs
GROSS WEIGHT	265 Lbs
CYLINDER CAPACITY	2 L (.52 gal)
BEATER TYPE	stainless steel
HOPPER MIXER	standard
POWER	1.6 Kw
SELF-CHECK	yes
LOW MIXTURE SENSOR	yes
FREQUENCY CONVERSION	yes

REFRIGERATION SYSTEM

NUMBER OF COMPRESSORS	1
COMPRESSOR BRAND	Aspera
COMPRESSOR CAPACITY	4094 Btu / hr
COMPRESSOR GAS	R404 A
GAS QUANTITY	500 g
REFRIGERATION TYPE	air cool / water cool

TRANSMISSION

NUMBER OF MOTORS	1
MOTOR CAPACITY	550 W

Features:

- Single hopper, single flavor
- Offers all of the popular soft serve variations from low to non-fat ice creams, custards, yogurt, Italian ices and sorbet

CONTINUOUS DISCHARGING ABILITY

- Ensures continuous discharge even during peak hours

STAND-BY FUNCTION

- Stand-by option for both hopper and cylinder
- Ensures that product temps are maintained for safety

IMPORTED CORE ACCESSORIES

- Aspera compressors and Danfoss expansion valves
- Ensures the service life of the machines

SPRING HANDLE

- Automatic handle return
- Prevents ice cream overflow / reduces mess when not in use



Product List:

SERIAL NUMBER	COOLING TYPE	VOLTAGES
S930FA1	air cool	220 v / 50 hz 1P
S930FAP1	air cool	220 v / 50 hz 1P
S930FW1	water cool	220 v / 50 hz 1P
S930FWP1	water cool	210 v / 50 hz 1P
S930FA2	air cool	220 v / 60 hz 1P
S930FAP2	air cool	220 v / 60 hz 1P
S930FW2	water cool	220 v / 60 hz 1P
S930FWP2	water cool	220 v / 60 hz 1P

distributed by:
www.frozensolutions.com
888-698-1711

