

# S230F Soft Serve Twin Twist Freezer Table Top

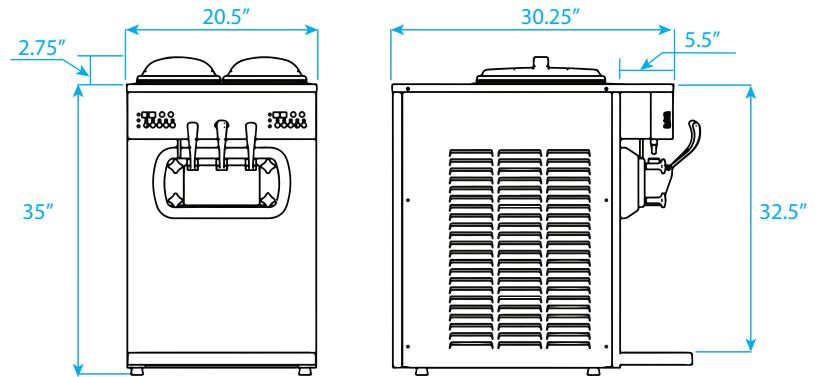

www.pasmousa.com  
1-844-527-2766



## Technical Specs:

### GENERAL INFO

MODEL NUMBER	S230F
TYPE	table top
PRODUCTION CAPACITY	30 L / H
NUMBER OF FLAVORS	3
NUMBER OF HOPPERS	2
HOPPER CAPACITY	9.5 L (2.5 gal)
SPECIFICATIONS	30.25" x 20.5" x 38"
CARTON SIZE	34.25" x 25" x 42.5"
NET WEIGHT	370 Lbs
GROSS WEIGHT	421 Lbs
CYLINDER CAPACITY	1.6 L (.42 gal)
BEATER TYPE	stainless steel
HOPPER MIXER	standard
POWER	3 Kw
SELF-CHECK	yes
LOW MIXTURE SENSOR	yes
FREQUENCY CONVERSION	yes

### REFRIGERATION SYSTEM

NUMBER OF COMPRESSORS	2
COMPRESSOR BRAND	Aspera
COMPRESSOR CAPACITY	3753 Btu / hr x 2
COMPRESSOR GAS	R404 A
GAS QUANTITY	500 g
REFRIGERATION TYPE	air cool / water cool

### TRANSMISSION

NUMBER OF MOTORS	2
MOTOR CAPACITY	550 W x 2

## Features:

- Double control system: 2+1 twist flavors
- Offers all of the popular soft serve variations from low to non-fat ice creams, custards, yogurt, Italian ices and sorbet
- Serve two separate soft serve flavors, or an equal combination of both in a twist
- Redundant components use side while other side is off
- Self returning handles

### SILENT

- Mute function, suitable for all types of environments

### CONTINUOUS DISCHARGING ABILITY

- Ensures continuous discharge even during peak hours

### DISPENSE SPACE

- 3 7/8" of dispense space
- Can meet the needs of big cups or cake decorating

### IMPORTED CORE ACCESSORIES

- Aspera compressors and Danfoss expansion valves
- Ensures the service life of the machines

### SPRING HANDLE

- Automatic handle return
- Prevents ice cream overflow / reduces mess when not in use

### INTEGRATED CYLINDER

- Cornered ends prevent bacterial growth
- Easy to wash



## Product List:

SERIAL NUMBER	COOLING TYPE	VOLTAGES
<b>S230FA1</b>	air cool	220 v / 50 hz 1P
<b>S230FA2</b>	air cool	220 v / 60 hz 1P
<b>S230FA3</b>	air cool	380 v / 50 hz 3P
<b>S230FW1</b>	water cool	210 v / 50 hz 1P
<b>S230FW2</b>	water cool	220 v / 60 hz 1P
<b>S230FW3</b>	water cool	380 v / 50 hz 3P

distributed by:  
www.frozensolutions.com  
888-698-1711

